

EBR-MWS6

Ceiling microwave presence/absence detector

Overview



The EBR-MWS6 presence detectors are designed to provide automatic control of lighting via the Rapid lighting control system. They detect movement using a highly sensitive microwave detector. This works by emitting low power microwave signals and measuring the reflections as the signals bounce off moving objects.

When an area is occupied the Rapid system can be programmed to turn the lights on. When an area is no longer occupied the load will switch off after an adjustable time out period. An adjustable internal light sensor provides light level information to the Rapid system to allow lights to be kept off if sufficient daylight is present, and to enable maintained illuminance for dimming systems.

An integral IR sensor in the unit allows the unit to be commissioned, and used in conjunction with a remote control handset (part no: UHS) to:

- Act as a conventional dimmer
- Override the unit on or off
- Change the maintained illuminance lux setting

Features

Front features

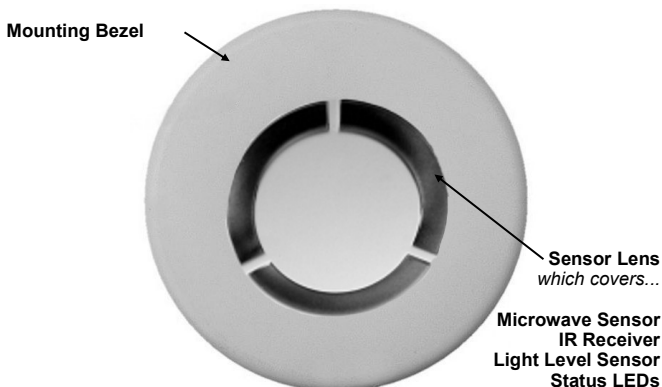

Microwave Sensor

Detects movement within the unit's detection range, allowing load control in response to changes in occupancy.

IR Receiver

Receives control and programming commands from an IR (infrared) handset.

Light Level Sensor

Measures the overall light level in the detection area

Status LEDs

Rapid bus connections

Two RJ45 connector for connection to Rapid LCM.

Back features

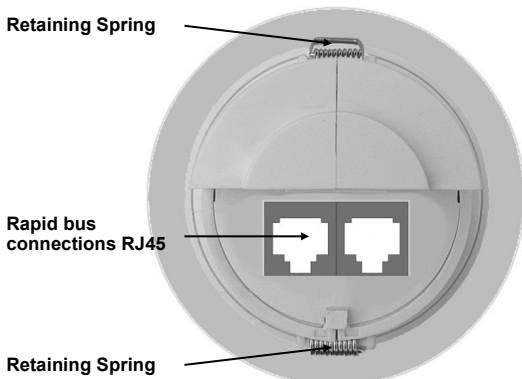

Detection diagram

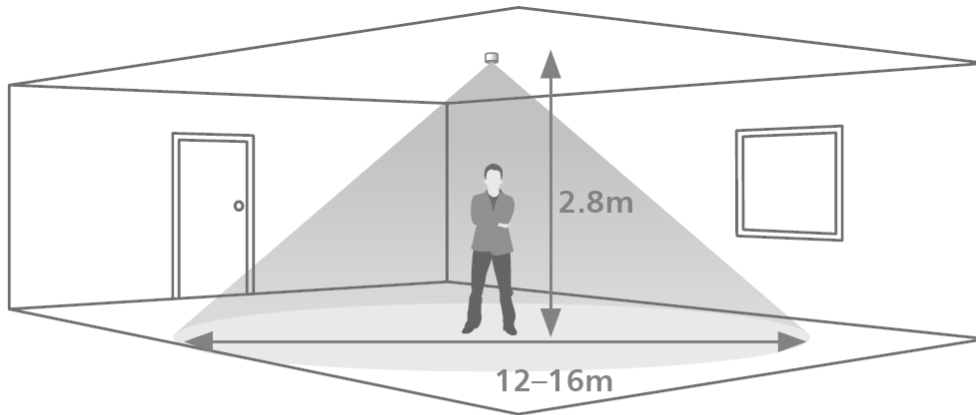

Area of high sensitivity  Area of lower sensitivity 

Note. If the range is compromised by the ceiling construction / material. Add the supplied 20mm spacer ring. See page 3 for fitting details.

Installation

Wire the products as in the diagram on page 1, simply by connecting to the relevant port of the Rapid LCM using a Cat5 patch cord. An additional RJ45 connector is provided to daisy chain sensors together.

The detector should be sited so that the occupants of the room fall inside the detection pattern shown above, at a recommended ceiling height of 2.8m.

Note that the higher the sensor is installed the shorter the detection range will be.

- Mount using one of the two options overleaf (for surface fixing order the DBB as a separate item).
- Do not site within 1m of any lighting or ventilation equipment.
- Do not fix to a vibrating surface.
- Site as far away as possible from the surface of metal objects.

Commissioning

Commissioning will normally be performed by our trained commissioning engineers.

Please note that prior to commissioning, it is the responsibility of the installing contractor to ensure the following:

- The RAPID LCMs must be connected and installed as described in the relevant datasheet
- The detectors must be installed and plugged into the channel of the LCM as shown on the system installation drawings
- Mains power must be available
- Luminaires must be plugged in
- Bus connection must be established and checked

The detector can be set up using our infrared programming handset or computer front end. For programming details see the separate programming document.

The EBR-MWS6 is designed to be mounted using either:

- Flush fixing, or
- Surface fixing, using the optional Surface Mounting Box (part no. DBB).

Both methods are illustrated below.

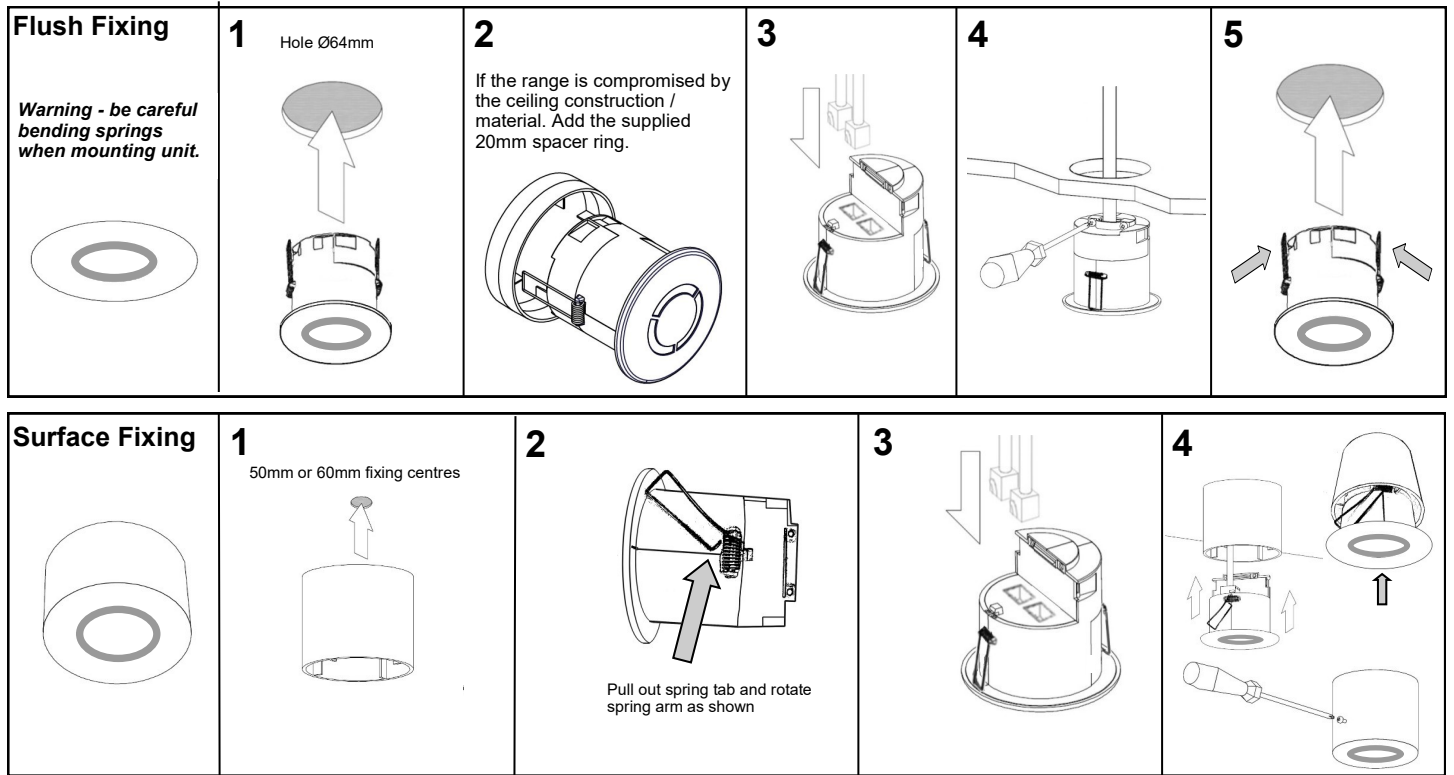

Technical data

Dimensions	See diagrams opposite
Weight	0.15kg
Supply Voltage	12VDC
Load	See Rapid LCM product guide
Timeout period	Adjustable 1 minute to 99 minutes
Light level	Light to dark
Terminal Capacity	2.5mm ²
Temperature	-10°C to 50°C
Humidity	5 to 95% non-condensing
Material (casing)	Flame retardant ABS and PC/ABS
Type	Class 2
Microwave frequency	5.8 GHz
Safety	The microwave radiation emitted by these units is extremely low power and complies with ANSI standard "IEEE95.1-1999 Standard for Safety Levels with Respect to Human Exposure to Radio Frequency Electromagnetic Fields 3kHz 300GHz."
IP rating	IP40
Compliance	RED-2014/53/EU LVD-2014/35/EU
For further compliance information visit www.cpelectronics.co.uk/compliance	



EBR-MWS6

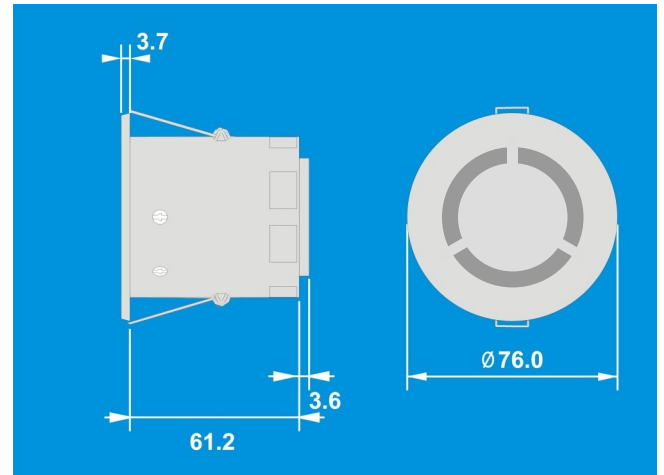

DBB

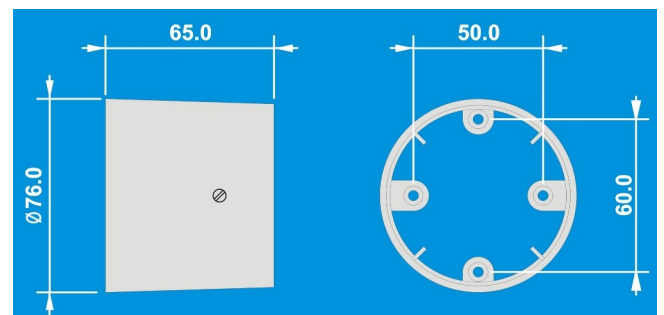

Part numbers

	Part number	Description
Detector	EBR-MWS6	Ceiling microwave presence detector
Accessories	DBB	Surface mounting box
	UNLCDHS	Universal LCD IR handset

IMPORTANT NOTICE!

This device should be installed by a qualified electrician in accordance with the latest edition of the IEE Wiring Regulations and any applicable Building Regulations.



C.P. Electronics Ltd
Brent Crescent
London
NW10 7XR
United Kingdom
Tel: +44 (0) 333 900 0671
Fax: +44 (0) 333 900 0674
www.cpelectronics.co.uk
enquiry@cpelectronics.co.uk